

1. CUT THE PIPE

Make certain that the pipes are cut squarely and free of imperfections.

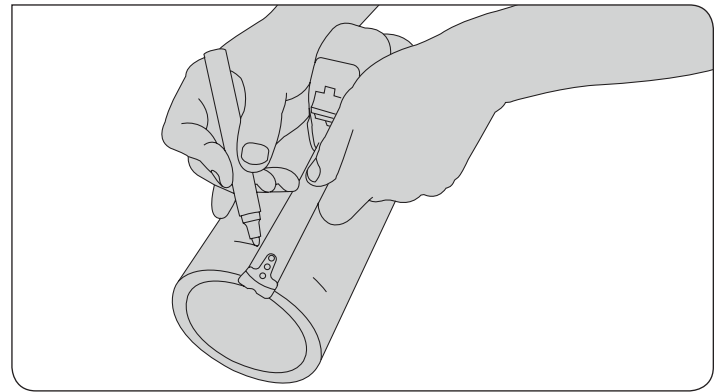

2. MEASURE FOR GASKET PLACEMENT

Measure and mark a minimum of 5 equally spaced lines around each of the pipes you will join. These lines will mark where the edge of the gasket should be, to ensure that the gasket is centered between the 2 pipes.

- 2" thru 4" pipe - mark 7/8" from the end of the pipe
- 6" pipe - mark 1" from the end of the pipe
- 8" thru 12" pipe - mark 1 1/16" from the end of the pipe

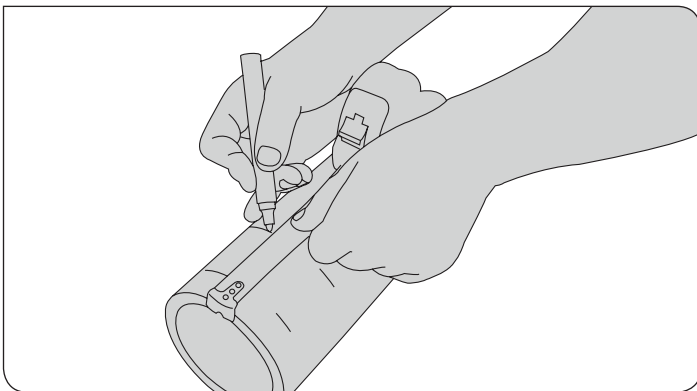

3. MEASURE FOR COUPLING PLACEMENT

Measure and mark another set of a minimum of 5 equally spaced lines around each of the pipes you will join. These lines will mark where the edge of the fitting should be, to ensure that the pipe placement is correct when the coupling is installed.

- 2" thru 4" pipe - mark 2 5/16" from the end of the pipe
- 4" thru 6" pipe - mark 3" from the end of the pipe
- 8" pipe - mark 3 1/16" from the end of the pipe
- 10" pipe - mark 3 1/4" from the end of the pipe
- 12" pipe - mark 3 9/16" from the end of the pipe

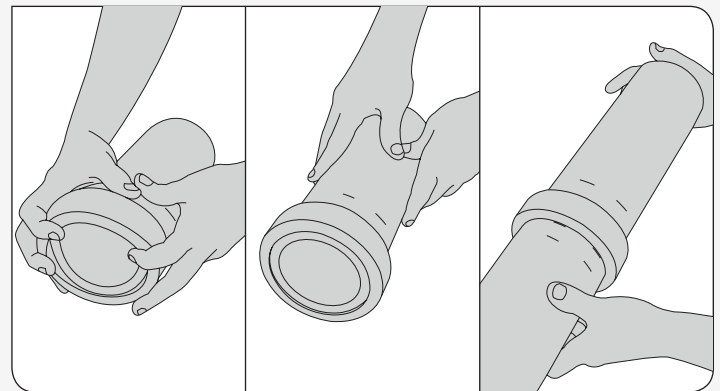

4. INSTALL GASKET

Ensure that the gasket is free from burrs or any imperfections and that the gasket material and size is acceptable for the intended service. Slide the gasket over the pipe end so that it is flush with the pipe end. Next, butt up against and center with the other pipe. Slide the gasket into place, so that it is equally covering both pieces of pipe. Use the first set of lines that you marked on the pipe as a guide to ensure proper placement, centering the gasket between the pipes.

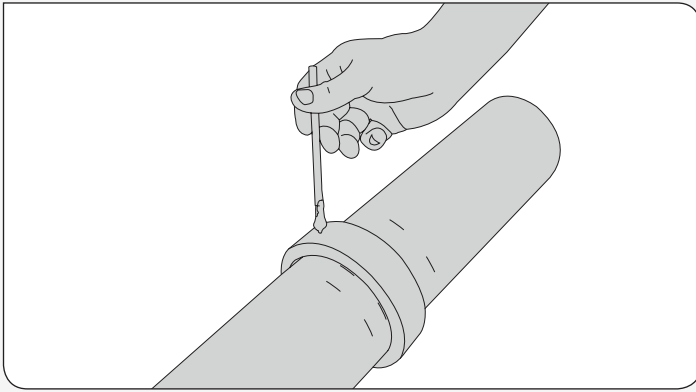

5. PREPARE GASKET

Apply a thin coating of lubricant on the exterior and lip of the gasket. We recommend only silicon based lubricant for our Nitrile gaskets. Please check with the pipe manufacturer to ensure that your chosen lubricant is compatible with the pipe.

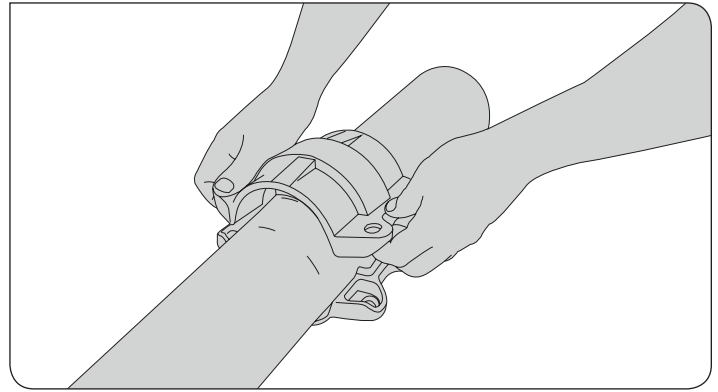

6. INSTALL HOUSINGS

Place the coupling halves over the gasket. Ensure that the two halves mate correctly, that the gasket stays centered on the pipe and that the pipes remain butted together. Use the lines that you marked on the pipe as a guide to ensure proper placement.

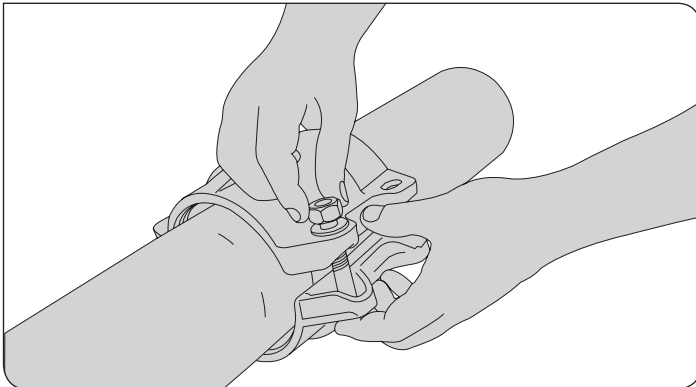

7. INSTALL BOLTS

Either a flanged nut or a nut and a washer are provided. Add washers (if provided) and hand tighten nuts.

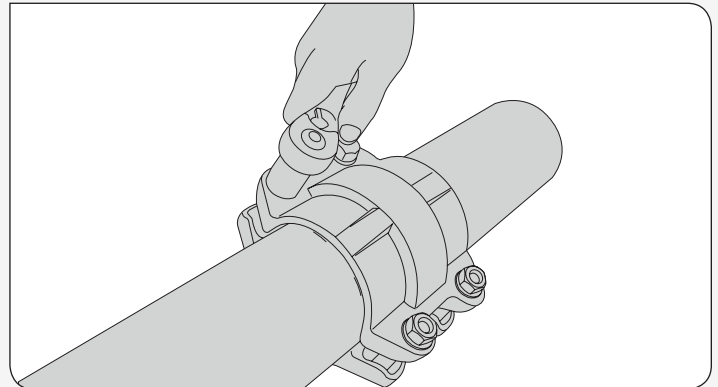

8. TIGHTEN NUTS

When metal to metal contact is achieved, bolt torque should fall within specified range.

SPECIFIED BOLT TORQUE

Specified bolt torque is for the oval neck track bolts used on Munro couplings. The nuts must be tightened alternately and evenly until fully tightened. CAUTION: Use of an impact wrench is not recommended because the torque output can vary significantly due to many variables including air pressure supply, battery strength and operational variations.

CAUTION

Proper torquing of coupling bolts is required to obtain specified performance. Over torquing the bolts may result in damage to the bolt and/or casting which could result in pipe joint separation. Under torquing the bolts may result in lower pressure retention capabilities, lower bend load capabilities, joint leakage and pipe joint separation. Pipe joint separation may result in significant property damage and serious injury.

BOLT TORQUE

Coupling Bolts	Minimum	Maximum
In.	Ft.-Lbs./N-m	Ft.-Lbs./N-m
1/2 X 2 3/8 (2" couplings)	80 110	100 150
1/2 X 3 (3" - 4" couplings)	80 110	100 150
5/8 X 3 1/2 (6" - 8" couplings)	100 135	130 175
3/4 X 4 3/4 (10" - 12" couplings)	130 175	180 245