

### HOW ON DEMAND CONTROLS WORK

**On Demand Controls are used to start the pump in response to system demand, without the need for a signal from an external device like an irrigation controller.**

Any drop in the line pressure is detected by a pressure switch which activates the pump. When the system pressure rebuilds and is high enough to cut-out the pressure switch, a flow switch takes over monitoring the system. If flow is present, the pump will continue to run. When flow stops, a time delay is activated to reduce short-cycling of the pump. After the delay times out, the pump shuts down.

If a line leak drops the pressure low enough, the pump will come on for the amount of time set on the time delay; and then shut off. To ensure the pump doesn't short-cycle, the time delay is set to approximately 1 minute.

### PIPEWORK REQUIREMENTS FOR PROPER OPERATION

1. Install a spring check valve before the pressure and flow switches – this keeps the pressure in the line upstream of the valve so the switches can operate properly.
2. Maintain 5x pipe diameter from each switch to avoid turbulence in the line.
3. Pressure switch can be plumbed into a 1/4" tee or cross right at the pump case.
4. Flow switch fits best into a 1" PVC slip bushing with a female thread, galvanized pipe or tee. Trim blade if necessary.

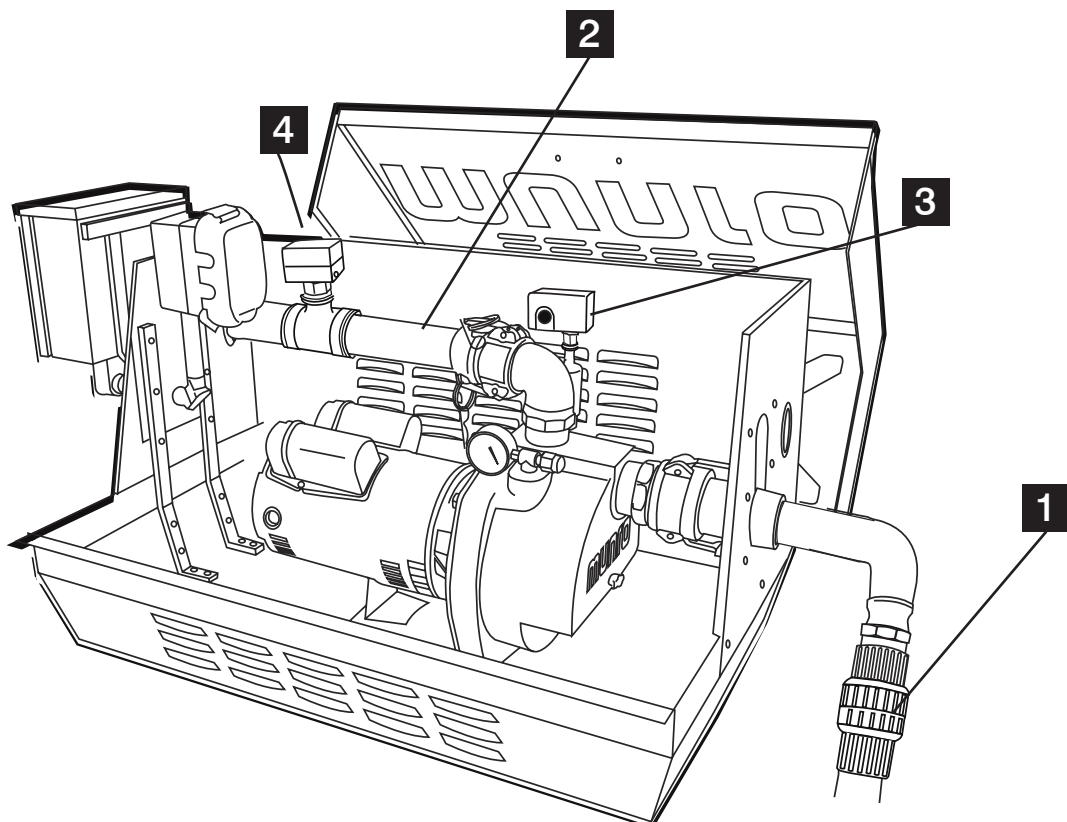

### WIRING REQUIREMENTS

#### Pressure Switch

- 1) Blue taped wire
- 2) L1 - M1 (or) L2 - M2
- 3) Make sure the pump can achieve cut-out pressure (switch range is 20-40 psi)

#### Flow Switch

- 1) Red taped wires
- 2) Wire to terminals B and C
- 3) Factory set to lowest flow setting
- 4) Field adjusting might be necessary since the spring tension is affected by line pressure

### TROUBLESHOOTING

#### If the pump does not come on

- 1) Check incoming power at contact.
  - a. If no power, check breaker.
- 2) Check fuses.
- 3) Make sure pressure switch has an Air Gap.
  - a. If not, lower cut-in pressure (refer to pressure switch settings).

#### If the pump does not shut off WITH NO FLOW

- 1) Check wiring – verify the flow and pressure switch are wired correctly and not crossed (common error).
- 2) Make sure copper contacts have an Air Gap and are open on the pressure switch.
  - a. If not, lower the cut-off pressure so the pump can achieve cut-out pressure, contacts must be open for the flow switch to be engaged.
    - i. **Cut-off pressure is reduced by turning the Range Adjustment screw counterclockwise. One turn equals 2-3 psi.**

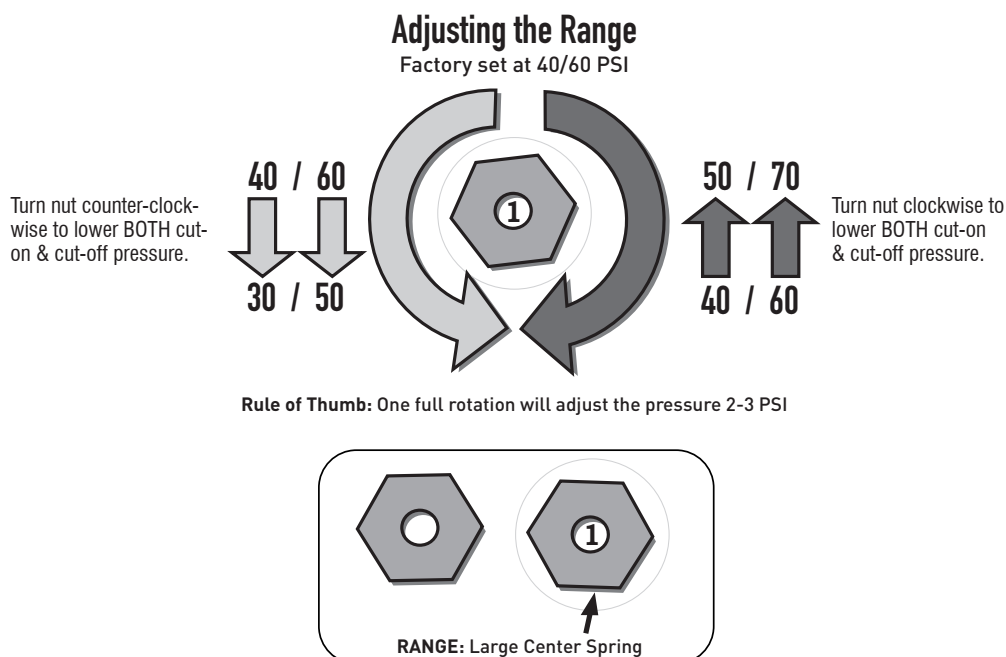

There are very few applications where you should adjust the differential. Adjusting the differential will only adjust the cut-off pressure. Turn the differential nut counterclockwise to lower cut-off pressure or turn the nut clockwise to raise cut-off pressure.

### TROUBLESHOOTING CONT.

- 4) Check Time Delay – ON light should be illuminated with no flow.
- 5) If ON is not illuminated, adjust flow switch.
  - a. Loosen set nut on spring-loaded adjustment screw.
  - b. Turn counterclockwise until ON light illuminates.
  - c. Double check spring tension by pulling the lever out to activate the micro switch.
    - i. ON light should go off.
    - ii. Release lever ON light should illuminate.
  - d. Re-tighten set nut.



TIME DELAY

### ADJUSTMENT INSTRUCTIONS

<p>1) Locate and loosen the set nut on the spring-loaded adjustment screw.</p>	<p>2) Use a screwdriver to change the flow rate engagement.</p>	<p>3) Verify the adjustment is within parameters of sensor.</p>	<p>4) Once the adjustment is complete, tighten the set nut again – repeat step 3.</p>

When the adjustment screw is rotated ccw, it adjusts the switch reading closer to max flow rate (shortens the spring).  
 When the adjustment screw is rotated cw, it adjusts the switch reading closer to min flow rate (lengthens the spring).  
 Factory setting is at lowest setting.

### CONVERSION INSTRUCTIONS

#### Steps to convert a standard Complete PRO to On-Demand.

- 1) Shut off breaker to Complete PRO.
- 2) Replace the existing control panel.
  - a. Mounting a 12 x 12 electrical box requires expansion brackets not used on smaller electrical boxes.
- 3) Remove the discharge hose.
- 4) Repipe according to the “Pipework Requirements” section above.
- 5) Turn breaker on.
- 6) Test/adjust sensors for application specifics.



For troubleshooting assistance,  
contact Technical Customer Support.

**Phone: 1.800.942.4270**

**Email: [technicalsupport@munropump.com](mailto:technicalsupport@munropump.com)**

**[www.munropump.com](http://www.munropump.com)**