

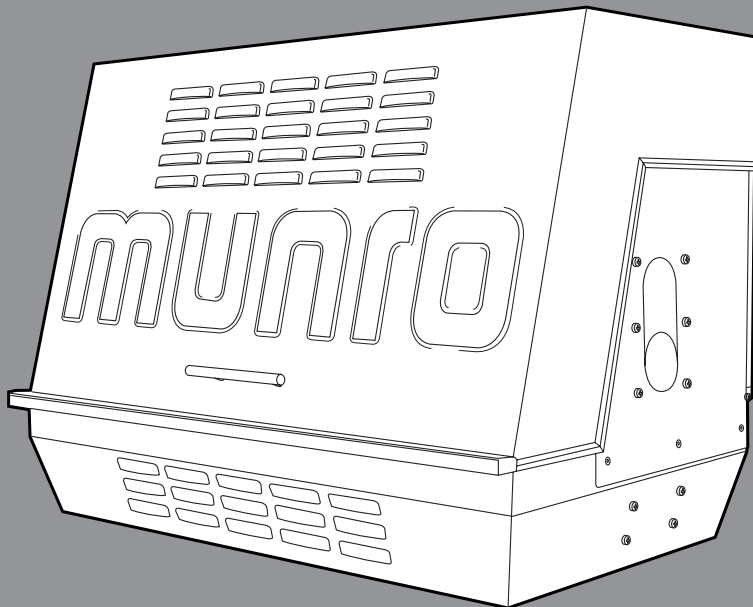

ASSEMBLY GUIDE

Universal PRO Enclosure



Assembly - Parts

Phone: 1.800.942.4270
Email: mpi@munropump.com

munro

Universal PRO Enclosure Assembly Guide

PARTS

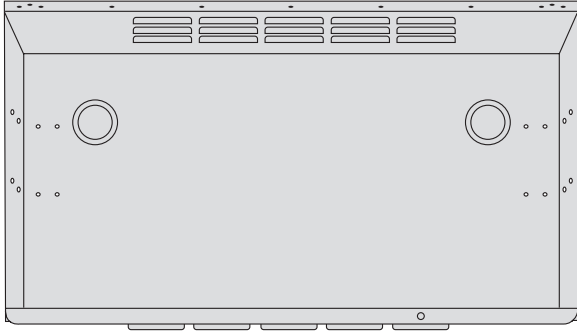

Base (1)

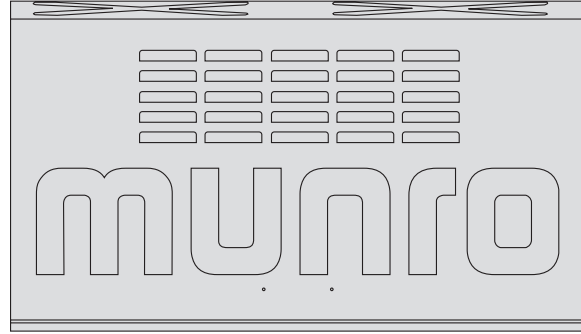

Lid (1)

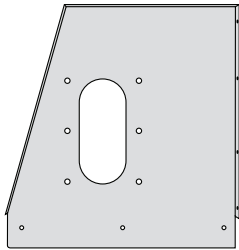

Left Sidewall (1)

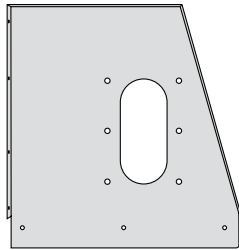

Right Sidewall (1)

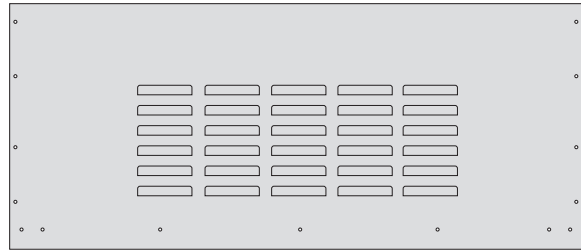

Back Wall (1)

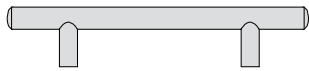

Handle (1)

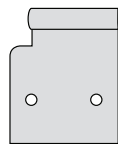

Left Hinge (1)

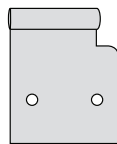

Right Hinge (1)

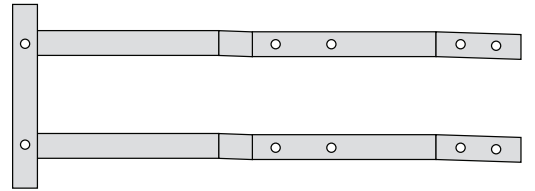

Control Box Bracket (1)

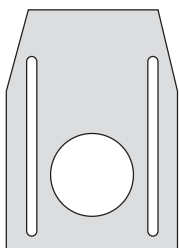

Suction Pass-through Panel (1)

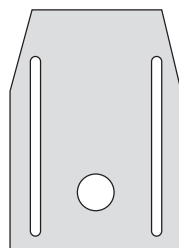

Electrical Pass-through Panel (1)

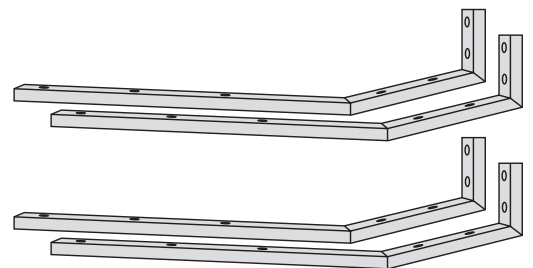

L-Brackets (4)

Universal PRO Enclosure Assembly Guide

FASTENERS



Rivet Pack (50)

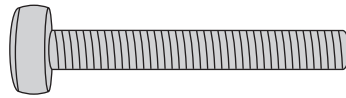

Phil Pan (Hinge) Screw 1-1/2" (2)

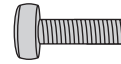

Handle Screws 1/4" (2)

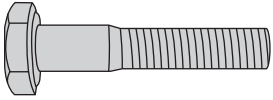

1/4-20 x 1-1/4" Bolt (8)

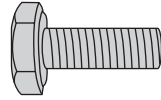

1/4-20 x 5/8" Bolt (22)



1/4-20 Hex Nut, SS (30)

TOOLS NEEDED FOR ASSEMBLY

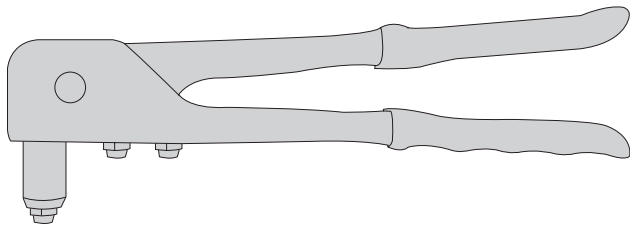

Riveter - Included

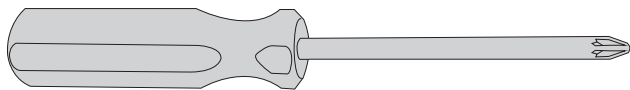

Phillips Head Screwdriver

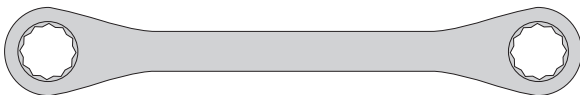

1" Box Wrench
(used for changing configuration)

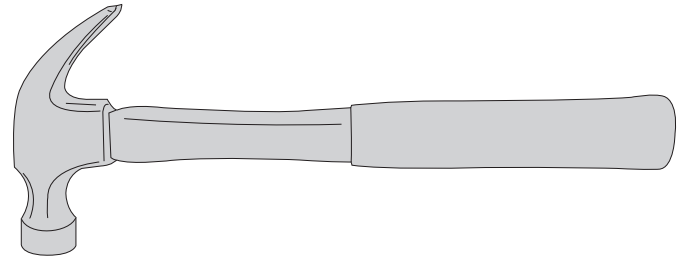

Hammer

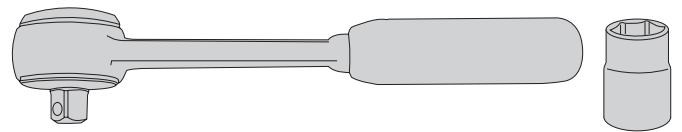

Socket Wrench with 7/16" Socket
(used for changing configuration)

CONSIDERATIONS BEFORE BEGINNING ASSEMBLY

Before beginning assembly, consider how you will want to configure your pump enclosure. Especially note:

- Which direction you want the pump to face, inside the enclosure.
- Intake placement, including side and the height requirement.
- Discharge placement, including which knockout will be used. Typically, will be opposite the intake side.
- Placement of the pump control box. Will it be mounted on the enclosure with the bracket provided or mounted somewhere else, such as near the irrigation controller.

Universal PRO Enclosure Assembly Guide

Step 1 – Installing the sidewalls

- Identify the left and right side walls. Note: the folded edges face the inside.

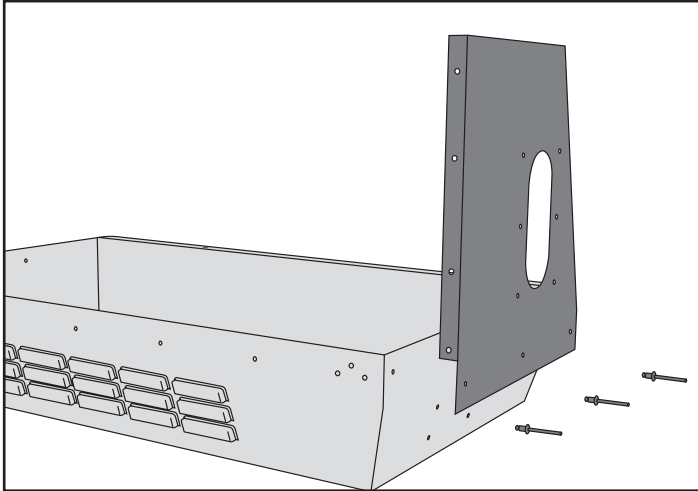

- Holding the sidewall in place, line up the three holes at the bottom of the sidewall with the three holes on the sides of the base.
- Secure the rivets in place using the handheld rivet gun provided (gun head may need to be changed to accommodate the rivet size). You will need to pump the gun several times to securely affix the rivet.

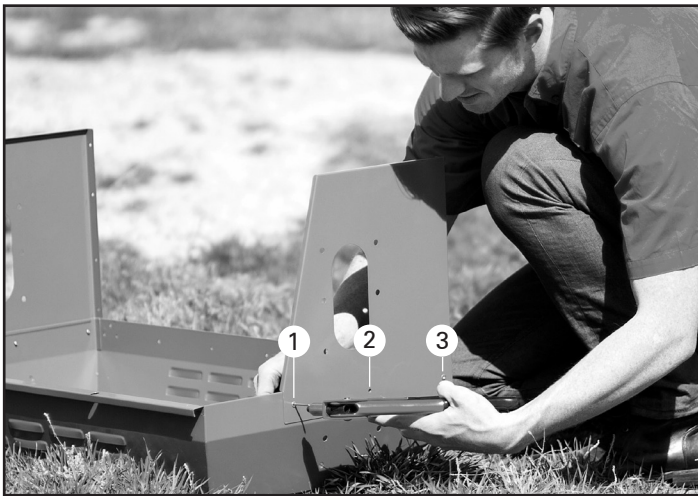

Step 2 – Installing the back wall

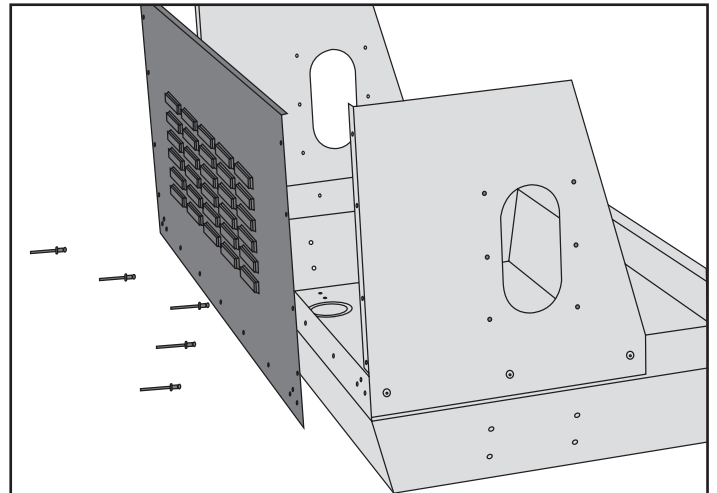

- Hold the back wall in place, with the vents facing out. Line up the middle hole at the bottom of the back wall with the middle hole on the back of the base. Secure the first rivet in place.
- Secure the bottom of the back wall by riveting the remaining four holes along the bottom.

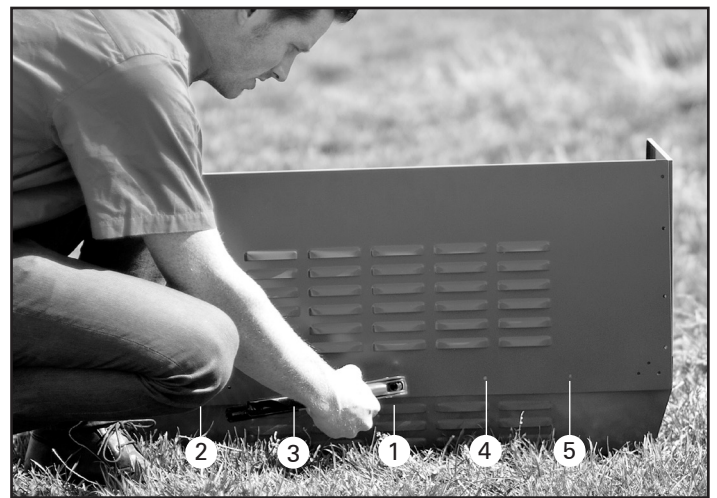

- Affix the sides of the back wall to the sidewalls by securing four rivets along each side of the back wall.



Universal PRO Enclosure Assembly Guide

Step 3 – Affixing the hinge plates

- Identify the right and left hinge plates. Note that the notches in the hinge plates should be in the outer, upper corners to accommodate the hinge pin.

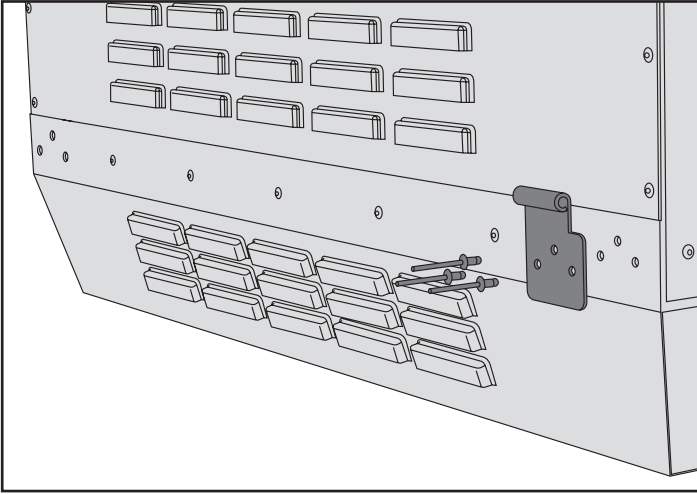

- Line up the right-side hinge plate with the three holes on the far right of the back wall.
- Affix the right-side hinge plate to the back wall by securing three rivets in the three holes.
- Repeat steps to secure the left-side hinge plate.

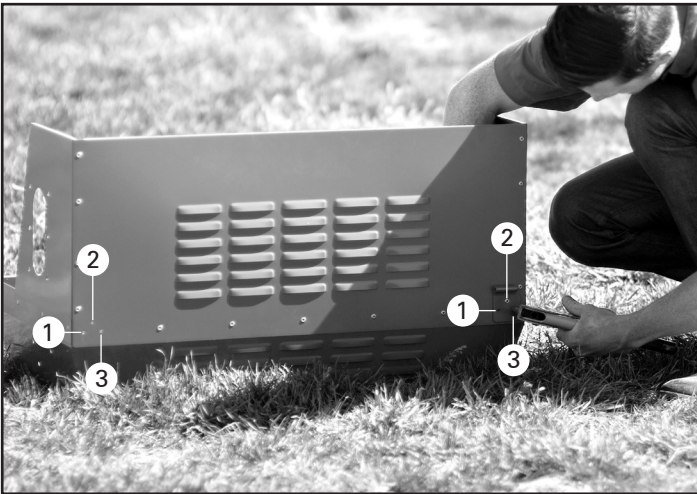

Step 4 – Knocking out the discharge at the base of the enclosure

- Determine which discharge knockout you would like to utilize. Note: this is typically opposite the intake side.

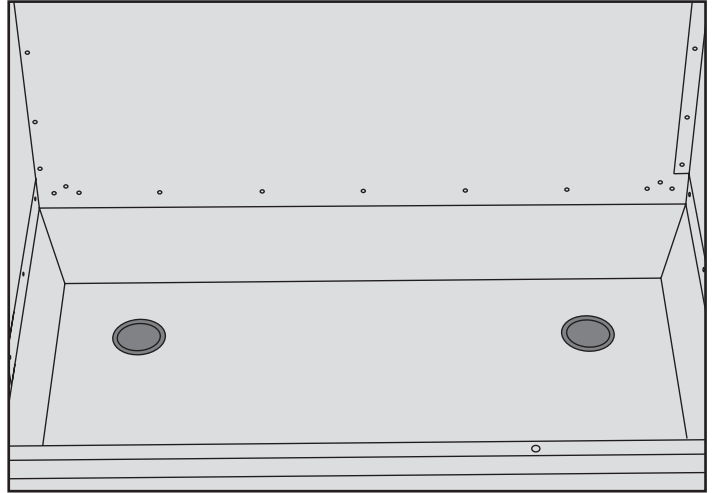

- Using a hammer, knockout the interior circle, focusing on the two metal tabs, to free the knockout.



Universal PRO Enclosure Assembly Guide

Step 5 – Attaching the side braces

- Identify the 4 L-braces, the control box bracket, the 22 short brace bolts, 8 long brace bolts and 30 nuts.

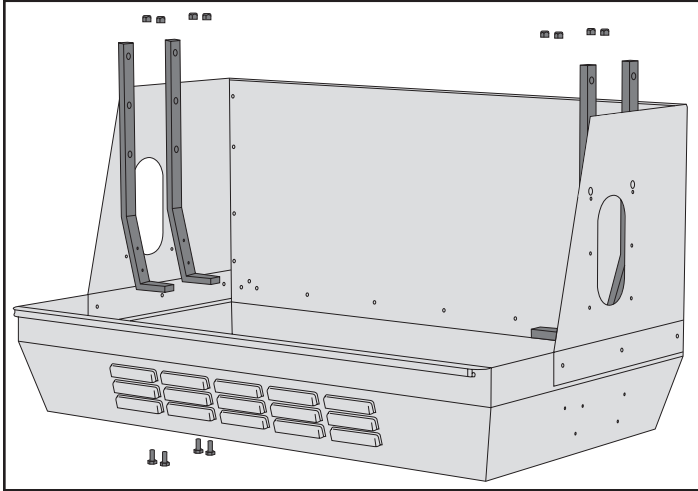

- Line up the L-braces with the holes in the inside of enclosure. Note: The L-braces are not left/right specific.
- Secure 2 short bolts in the holes in the bottom of each L-brace to the corresponding holes in the bottom of the enclosure.
- Determine on which side of the enclosure you will place the pump control box (the pump control box braces are shown on the left side in the below illustration but can be installed on either side of the enclosure). Note: Plan to install your suction line on the opposite side of the enclosure.

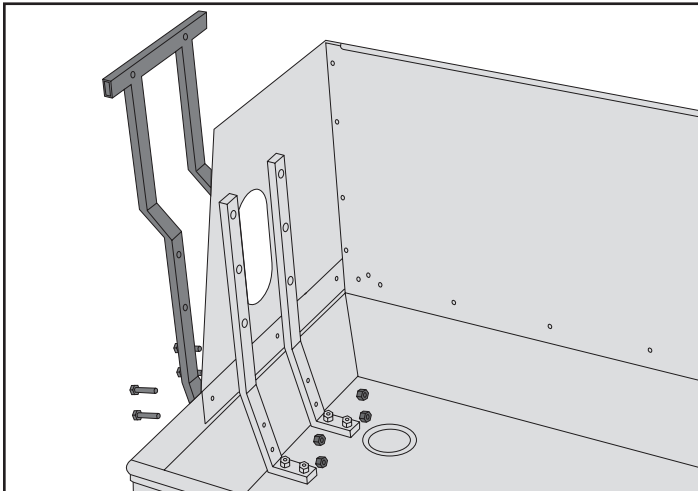

- Holding the pump control box braces in place on the outside of the enclosure, secure 2 long bolts in the holes toward the bottom of each L-brace to the corresponding holes in the side of the enclosure.

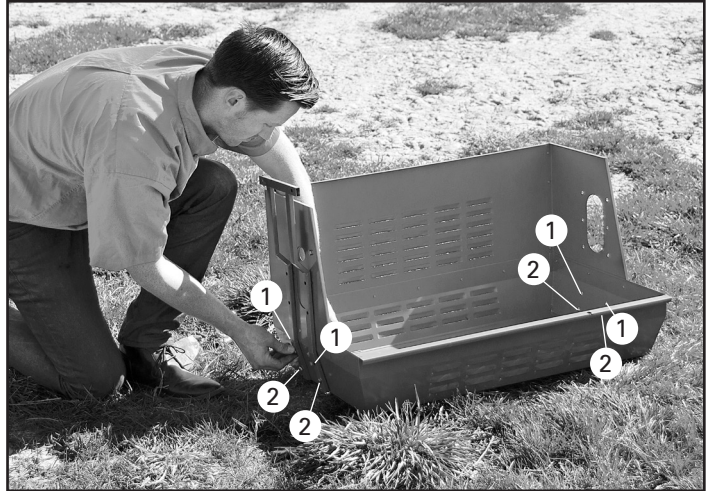

- On the opposite side of the enclosure, secure 2 long bolts in the holes toward the bottom of each L-brace to the corresponding holes in the side of the enclosure.
- If pump control box bracket is not used, simply install interior braces with long bolts in lower L-brace side holes.
- Do not fully tighten nuts and bolts until all braces and side pass-throughs are in place.

Universal PRO Enclosure Assembly Guide

Step 6 – Installing suction and electrical pass-through panels

- Identify the suction pass-through panel and the electrical pass-through panel. These panels can be installed on either side of the enclosure, to best suit your application. Note: The suction line should not be installed on the same side as the pump control box.

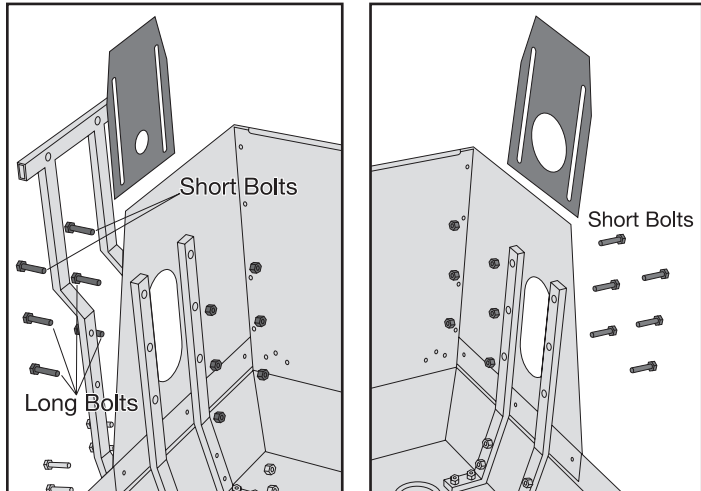

- Slide the appropriate pass-through panels into place on the inside of the sidewalls of the enclosure, between the sidewalls and the L-braces.
- Affix the pass-through panels at the appropriate height using 1 short and 2 long bolts in the upper part of each L-brace. Long bolts are necessary to pass through both braces. Short bolts are used when only passing through one brace. Note: The pass-through panels can be used in either direction to achieve the desired height.
- Tighten all nuts and bolts with a socket and wrench.

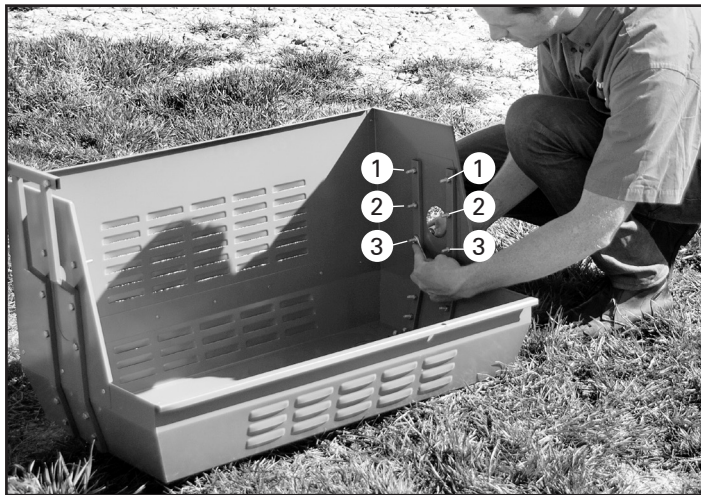

Step 7 – Attaching the lid

- Identify the hinge screws.
- Place the assembled lid in the “open” position, next to the assembled bottom.

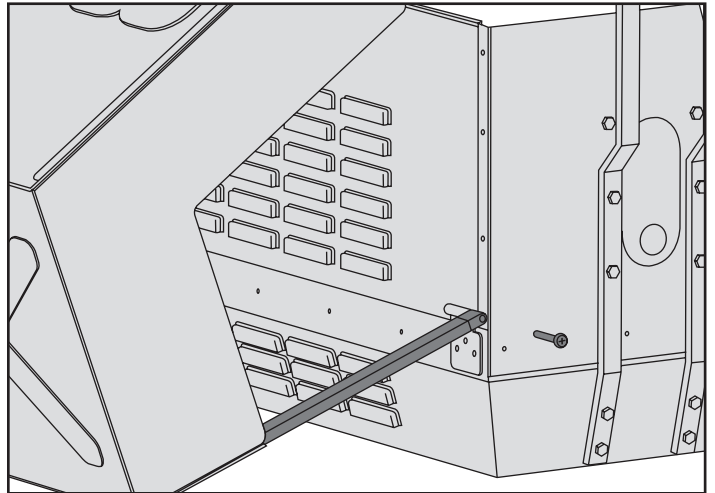

- Thread the screws through the end of the hinge arm on the lid of the enclosure and the hinge plate on the bottom of the enclosure.



Universal PRO Enclosure Assembly Guide

Step 8 – Attaching the handle

- Identify the handle and the handle screws.
- Place the assembled lid in the “open” position.

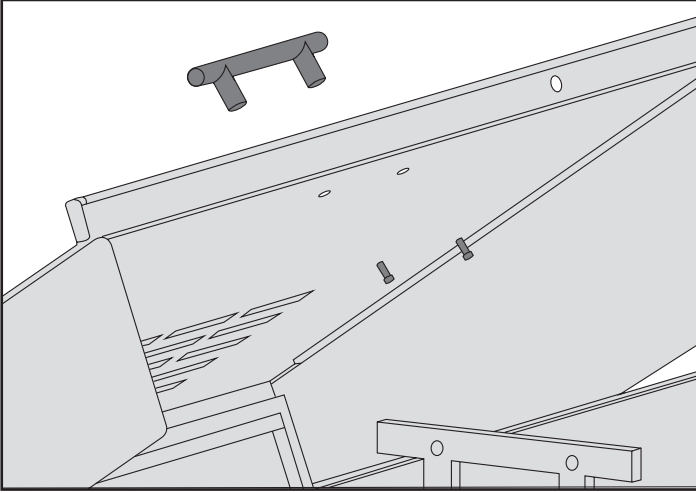

- Line up the holes in the back of the handle with the holes in the front of the enclosure.
- Use your Phillips head screwdriver to thread the handle screws through the inside of the lid and into the holes in the handle.

